

Trial Measurement #3 – “New Driveway”

Useful formulas:

Area of a circle = πr^2	Circumference of a circle = πd
Area of a parallelogram = $b h$	
Area of a triangle = $\frac{1}{2} b h$	$\pi = 3.14159$

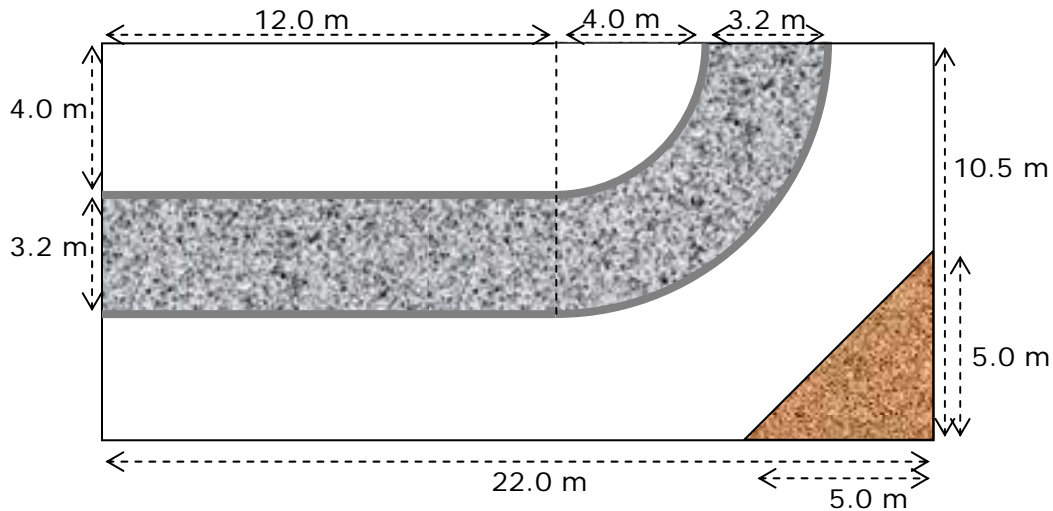

The Smiths are having their driveway area (22 metres by 10.5) metres completely redone.

The new drive is going to be 3.2 metres wide the whole of its length. The first part is 12 metres of straight line, followed by a quarter circle with an inner radius of 4 metres. The driveway is to be concrete, which must be at least 10 centimetre deep.

In one corner a triangular garden is going to be put in, 5 metres by 5 metres. They want it to have 5 centimetres deep of bark on it.

Once the work is finished, the whole area not in driveway or bark will need to be re-grassed.

Task

Before the driveway is poured, the sides (but not ends) will need to be edged. Calculate how many metres of edging will be required.

How much concrete, in cubic metres, will need to be ordered for the driveway?

How much bark, in cubic metres, will need to be ordered for the triangular garden area?

How much area will be left to be re-grassed?

Discuss any limits of accuracy, and how that might affect your answers above.

Answers: Trial Measurement #3 – “New Driveway”

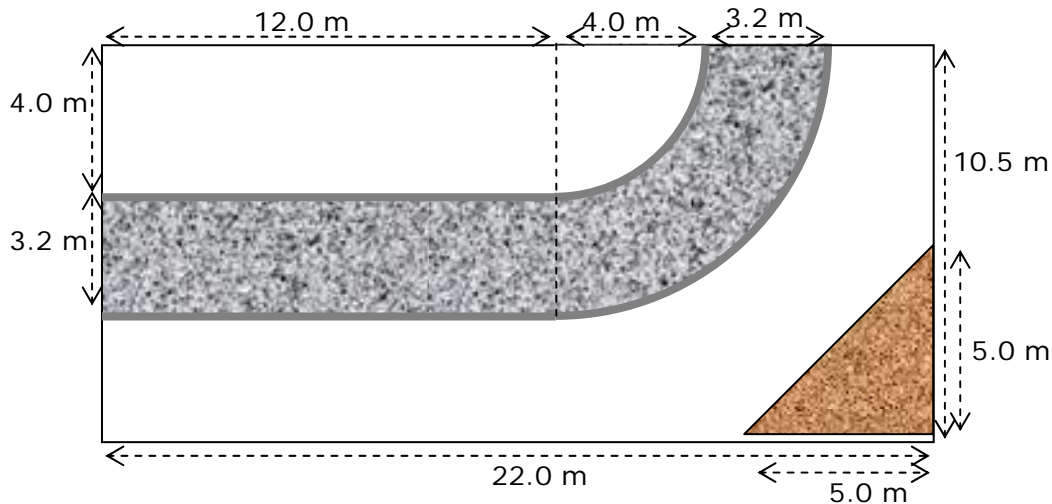

The edging is two straight sections and two curved sections, of radius 4 and 7.2 (= 4 + 3.2).

Length = straight + straight + $\frac{1}{4} \times \pi \times d$ + $\frac{1}{4} \times \pi \times d$

$$= 12 + 12 + \frac{1}{4} \times \pi \times (2 \times 4) + \frac{1}{4} \times \pi \times (2 \times 7.2) = \mathbf{41.6 \text{ metres}}$$

If the measurements are all a bit short measured, then the maximum it is likely to be is

$$= 12.05 + 12.05 + \frac{1}{4} \times \pi \times (2 \times 4.05) + \frac{1}{4} \times \pi \times (2 \times 7.3) = 41.93 \text{ metres}$$

So 42 metres of edging should cover it.

The volume of concrete is area \times depth, where area is a rectangle and outer quarter circle minus inner quarter circle, and depth is > 0.1 metres.

$$\text{Volume} = (3.2 \times 12 + \frac{1}{4} \times \pi \times 7.2^2 - \frac{1}{4} \times \pi \times 4^2) \times 0.1 = 66.58 \times 0.1 = \mathbf{6.658 \text{ m}^3}$$

Assuming the measurements are all a bit long, and that the depth has to be 11 cm on average to make sure none of the driveway depth is under 10 cm.

$$= (3.25 \times 12.05 + \frac{1}{4} \times \pi \times 7.3^2 - \frac{1}{4} \times \pi \times 4.05^2) \times 0.11 = \mathbf{7.49 \text{ m}^3}$$

It would be best to order at least 7.5 m^3 (probably 8 m^3 , just in case of spills etc)

Bark required is area \times depth, where depth is 0.05 metres

$$\text{Bark volume} = \frac{1}{2} \times \text{base} \times \text{height} \times \text{depth} = \frac{1}{2} \times 5 \times 5 \times 0.05 = 12.5 \times 0.05 = \mathbf{0.625 \text{ m}^3}$$

If the measurements are all a bit long, then the maximum it is likely to be is

$$= \frac{1}{2} \times 5.05 \times 5.05 \times 0.055 = \mathbf{0.7013 \text{ m}^3}$$

Since depth is not vital, 0.7 m^3 should be plenty

Area to regross is outer rectangle – driveway area – garden area.

$$\text{Area for grass} = 22 \times 10.5 - 66.58 \text{ (done above)} - 12.5 \text{ (done above)} = \mathbf{151.92 \text{ m}^2}$$

*Area largest if the rectangle is larger, and the driveway + garden are **smaller**.*

$$= 22.05 \times 10.55 - (3.15 \times 11.95 + \frac{1}{4} \pi 7.1^2 - \frac{1}{4} \pi 3.95^2) - \frac{1}{2} \times 4.95 \times 4.95$$

$$= 232.63 - 64.98 - 12.25 = 155.37$$

The area to be regressed may be as large as 156 m^2 .

Achieved is any three correct calculations from: perimeter, circular area, triangle area and volume (even if the end calculation shown in bold is not reached).

Merit is three of four correct overall calculations shown in bold (allowing errors to carry over).

Excellence needs discussion of errors as well, more or less in line with the calculations shown.